

Segnalatore luminoso snodabile a led con o senza lampeggio
 Rotating signal light with L.E.D. with fixe or flashing light
 Lampe de signalisation giratorie avec L.E.D avec ou sans clignote
 Schwenbar Blinkleuchte mit oder ohne blinkend mit l.e.d.
 Lampara L.E.D. con rotacion con o sin relampagueo

100%
 ITALY



SNOD-LED-FULL

new

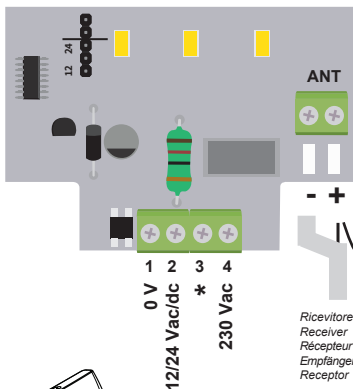

Collegare al morsetto + con l'anima del cavo schermato, collegato al ricevitore, un cavo rigido di lunghezza:

Connect the shielded cable to the terminal +, connect the antenna cable to the receiver:

Brancher le câble blindé sur le bornier +, il faut brancher sur le recepateur le câble d'antenne:

Verbinden das abgeschirmetes Kable zur Klemmleiste +.

Verbinden die Antenne Kabel zum Empfänger:

Conectar un cable blindado en el terminal +, conectar al receptor el cable de antena:

17cm 433Mhz - 8.5cm 868 Mhz

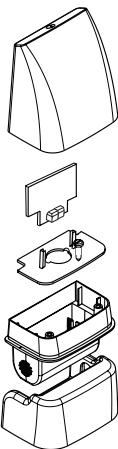

**Alimentazione / Power supply /
 Alimentation / Stromversorgung
 / Alimentación**



230 Vac



24 Vac/dc



12 Vac/dc

	Luce fissa Fix light Lumière fixe Festes licht Luz fija
	Lampeggio Flashing light Clignote Blinkend Luz parpadeante

* Collegare tra i morsetti 1-3 nel caso in cui si voglia il lampeggiante luce fissa e con tensione maggiore di 28Vac/30Vdc.

Connect between terminals 1-3 in case you want the light fixed and with voltage greater than 28Vac/30Vdc.

Connectez-vous entre les bornes 1-3 au cas où vous souhaitez que la lumière fixe et avec une tension supérieure à 28Vac/30Vdc.

Caratteristiche generali / General details / Caracteristiques / Beschreibung / Características generales

Il contenitore è a prova di infiltrazione in polycarbonato antiurto non necessita quindi di gabbia di protezione.

Box is waterproof, made of polycarbonate, anti-crash, and it is not necessary an anti-vandal protection.

Le boîtier est à preuve d'infiltration en polycarbonate antichoc et il n'y a pas besoin d'une protection anti-vandale.

Das Gehäuse besteht aus Polycarbonat , Stossfest und man braucht keine Schutzmaske.

La lámpara está a prueba de golpes, fabricado en polycarbonato antivandálico. No necesitando una jaula de protección.

Caratteristiche tecniche / Characteristics / Caractéristique technique / Características técnicas

alimentazione / power supply / alimentation / alimentación	Vac/dc	12/24 Vac/dc 230 Vac
potenza / power / puissance / potencia	Watt	1
temperatura d'esercizio / operating temperature / temperature / temperatura de funcionamiento	°C min/Max	-20°C++60°C EN 600068-2-1EN 600068-2-2
grado di protezione / protection / degré de protection / protección	IP	65 EN 60529
contenitore / cover / boîtier / tapa exterior		polycarbonato / polycarbonate
dimensioni / dimensions / dimensions / dimensiones	mm	b95 x h152/165 x p65

Dichiarazione CE di conformità / EC Conformity declaration / Déclaration de conformité / Declaración CE de conformidad

Il costruttore / the constructor / le fabricant /
el fabricante

DICHIARA CHE:
DECLARES THAT:
DÉCLARE QUE:
DECLARA QUE:



nome prodotto: SNOD-LED-FULL
name of the product: lampeggiante / flashing light /
nome produit : feu de signalisation /
nombre de producto: relampagueante

IL PRODOTTO E' CONFORME a quanto previsto dalla direttiva comunitaria:
THE PRODUCT CORRESPONDS to the european directives:
LE PRODUIT EST CONFORME a ce qui est prévu par la directive communautaire:
EL PRODUCTO CORRESPONDE a las directivas europeas:

2006/42/CE
2014/30/CE
2014/35/CE

DIRETTIVA MACCHINE / MACHINERY DIRECTIVE / DIRECTIVE MACHINE / DIRECTIVA MAQUINARIA
DIRETTIVA COMPATIBILITA' ELETTROMAGNETICA (EMC) / EMC ELECTROMAGNETIC COMPATIBILITY DIRECTIVE / DIRECTIVE COMPATIBILITE'
ELECTROMAGNETIQUE / DIRECTIVA COMPATIBILIDAD ELECTROMAGNETICA (EMC)
DIRETTIVA BASSA TENSIONE E SUCCESSIVA MODIFICA / LOW VOLTAGE DIRECTIVE AND CONSECUTIVE CHANGES / DIRECTIVE BASSE
TENSION ET MODIFICATION SUIVANTS / DIRECTIVA DE BAJA TENSION Y LAS MODIFICACIONES POSTERIORES

Dairago, 14/06/2017

EB TECHNOLOGY S.r.l.
Corso Sempione 172/5,
21052 Busto Arsizio VA Italy

NOLOGO S.r.l.
Via A. Pacinotti 44,
20035 Villa Cortese MI Italy
tel. +39 0331.430457
fax.+39 0331.432496

L'Amministratore
Ernestino Bandera

posta@ebtechnology.it
www.ebtechnology.it

info@nologo.info
www.nologo.info

