

REACH Wireless®

Remote Indicator



Product overview

Product	REACH Wireless Remote Indicator
Part No.	RW1500-800APO
Digital Communication	Apollo protocol compatibility is handled via the Loop-Interface device, RW1700-030APO. See product for more detail.

Manufacturer's Specification

All data is supplied subject to change without notice. Specifications are typical at 24 V, 25°C and 50% RH unless otherwise stated.

Communication Range between Loop-Interface and Devices	100 m (in open space)
Field Device Radio Frequency Channel Pairs	22 pairs
Radiated Power	14 dBm (25 mW)
Battery Type	2x VARTA CR123A Lithium 3V, 1250mAh typical
Battery Lifespan	Five years in normal operation with good signal strength (no dropped messages)
Operating Temperature	-10°C to +55°C
Maximum Relative Humidity (non-condensing)	95%
IP Rating	IP 42
Dimensions	80 mm diameter x 80 mm height x 32 mm depth
Weight (including batteries)	60 g

Product information

The RW1500-800APO is a wireless addressable remote indicator that can be used to indicate the activation of an individual device or zone.

- Compatible only with REACH Wireless
- Red LED with large diffuser for greater visibility
- Bi-directional wireless communication
- Dual channel redundancy
- Five year product warranty

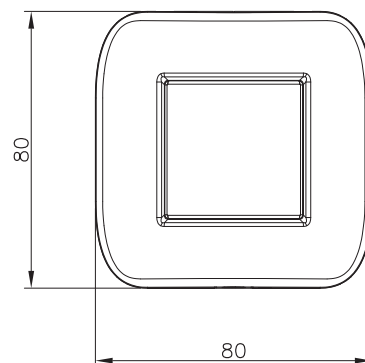
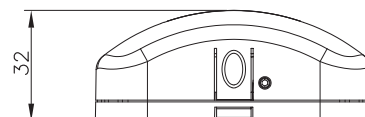

Status LED

The REACH Wireless Remote Indicator is equipped with a visual LED Indicator; LED signals indicate functional status of the device as per Table 1.

Table 1: REACH Wireless Device Status & LED Indication

Device Status	LED Indication
Power Up	Blinks green four times
Power Up (dip-switch ON)	Blinks red four times
Entering Wake-Up	Blinks alternatively green/red four times
Link Success	Blinks green four times, then repeats
Link Failure	Enters wake-up mode and signals 'Entering wake-up mode' following this failure
Normal Condition	LED off
Activation	LED on
Battery Faults	LED off
Tamper Fault	LED off
Replaced	Blinks green two times

Device Addressing

Device addressing is handled by the REACH Wireless Loop-Interface device (RW1700-030APO).

Devices are soft-addressed automatically when pairing with the Loop Interface and can be changed manually. Hard-addressing using Apollo XPERT cards are not supported.

Communication

REACH Wireless Devices use 'radio-frequency' wireless communication to connect to the Loop-Interface.

The Loop-Interface (RW1700-030APO) translates the wireless communication into wired Apollo protocol communication, with each device addressable individually by the fire panel. See datasheets for the Loop-Interface for more information.

Maintenance and Service

Maintenance must be performed in accordance with all applicable standards. Clean the detector externally using a soft damp cloth. For full cleaning and recalibration detectors should be returned to Apollo Fire Detectors.

Tamper detection

REACH Wireless devices contain an anti-tamper mechanism. In the event of removal from its base, it sends a tamper detection message to the Loop-Interface.

Tampering detection is not signalled visually by the device LED.

EMC Directive 2014/30/EU

REACH Wireless Remote Indicator complies with the essential requirements of the EMC Directive 2014/30/EU, provided that it is used as described in this datasheet.

A copy of the Declaration of Conformity is available from Apollo on request.

Construction Products Regulation (EU) 305/2011

The REACH Wireless Remote Indicator complies with the essential requirements of the Construction Products Regulation (EU) 305/2011

A copy of the Declaration of Performance is available from Apollo on request.